

1.0 Reference and Address			
Report Number	191120006GZU-001	Original Issued: 30-May-2022	Revised: None
Standard(s)	<p>Inverters, Converters, Controllers and Interconnection System Equipment for use with Distributed Energy Resources [UL 1741:2010 Ed.2+R:16Sep2020]</p> <p>Power Conversion Equipment [CSA C22.2#107.1:2016 Ed.4]</p> <p>Interconnecting Distributed Resources With Electric Power Systems (R2008) [IEEE 1547:2003]</p> <p>Amendment 1 to IEEE 1547 - Interconnecting Distributed Resources With Electric Power Systems [IEEE 1547a:2014]</p> <p>IEEE Standard Conformance Test Procedures For Equipment Interconnecting Distributed Resources With Electric Power Systems [IEEE 1547.1:2005]</p>		
Applicant	Dongguan Kaideng Energy Technology Co., Ltd	Manufacturer	Dongguan Kaideng Energy Technology Co., Ltd
Address	4th Floor, Fuyuan Commercial Building, No.1, Lane 13, Maiyuan Road, Xin'an Community Chang'an Town, DONGGUAN CITY, Guangdong	Address	4th Floor, Fuyuan Commercial Building, No.1, Lane 13, Maiyuan Road, Xin'an Community Chang'an Town, DONGGUAN CITY, Guangdong
Country	CHINA	Country	CHINA
Contact	Junping Deng	Contact	Junping Deng
Phone	86 13728323353	Phone	86 13728323353
FAX	--	FAX	--
Email	info@kaideng.com	Email	info@kaideng.com

2.0 Product Description					
Product	Utility-Interactive Micro Inverter				
Brand name	KaiDeng				
Description	Product covered by this report is isolated micro utility-interactive PV inverter which filled with potting compound and suitable for indoor or outdoor installation. The Microinverter is suitable for independent or interconnected used . These microinverters are designed to operate at full power at ambient temperatures 25°C, more than 25°C to 50°C would gradually derate to 0W and the housing is designed for outdoor installation and complies with the NEMA 3R environmental enclosure rating The inverter is intended for installation shall be in accordance with ANSI/NFPA 70, "National Electrical Code".				
Models	WVC-300, WVC-350, WVC-600, WVC-700, WVC-1200, WVC-1400				
Model Similarity	All models are identical except the dimension and combination of number of power module, for example, WVC-300 and WVC-350 are combined with 1 power module and derated by software, WVC-600 and WVC-700 are combined with 2 power modules and derated by software, WVC-1200 and WVC-1400 are combined with 4 power modules and derated by software.				
	Model	WVC-300	WVC-350	WVC-600	WVC-700
	DC input:				
	Range of input voltage:	22-60Vdc			
	Max. input voltage:	60Vdc			
	Max. input current of the MPP tracker:	12A	14A	12A*2	14A*2
	Max. input short circuit current:	15A	15A	15A*2	15A*2
	Max backfeed current:	0A			
	AC output:				
	Nominal output power	300W	350W	600W	700W
	Nominal grid voltage	240Vac			
	Range of grid voltage	212 - 262Vac			
	Nominal grid frequency	60Hz			
	Range of grid frequency	59.5 - 60.5Hz			
	Grid voltage and frequency trip times	See other ratings			
	Nominal output current	1.3A	1.52A	2.60A	3.04A
Max. output overcurrent protection	6.3A	6.3A	10A	10A	
Output power factor	> 0.95				
Enclosure	NEMA 3R				

2.0 Product Description			
Ratings	operation ambient temperature	-20 to +50°C (power deration above 25°C)	
	Software Version	WVC-350WC3	WVC-700WC3
	Max output fault current and duration (ac)	6.3Arms@10ms	10Arms@10ms
	Sychronization in-rush current	<1A	
	Trip limit and trip time accuracy	Voltage:1%; Frequency:0.1Hz Time:6%, but not less than 100ms	
	Output pwr temp derate/ max pwr ambient	50°C (power derating to 0W)	
	Model	WVC-1200	WVC-1400
	DC input:		
	Range of input	22-60Vdc	
	Max. input	60Vdc	
	Max. input current of the MPP tracker:	12A*4	14A*4
	Max. input short circuit current:	15A*4	15A*4
	Max backfeed current:	0A	
	AC output:		
	Nominal output	1200W	1400W
	Nominal grid	240Vac	
	Range of grid	212 - 262Vac	
	Nominal grid	60Hz	
	Range of grid frequency	59.5 - 60.5Hz	
	Grid voltage and frequency trip times	See other ratings	
	Nominal output current	5.21A	6.08A
	Max. output overcurrent protection	20A	20A
	Output power factor	> 0.95	
	Enclosure	NEMA 3R	
	operation ambient temperature	-20 to +50°C (power deration above 25°C)	
	Software Version	WVC-1400WC3	
	Max output fault current and duration (ac)	20A@10ms	
Sychronization in-rush current	<1A		
Trip limit and trip time accuracy	Voltage:1%; Frequency:0.1Hz Time:6%, but not less than 100ms		

2.0 Product Description					
	Output pwr temp derate/ max pwr ambient	50°C (power derating to 0W)			
Other Ratings	Voltage and frequency limits for utility interaction according to Table 1 and Table 2 per IEEE 1547a-2014				
	Default settings^a				
	Voltage range (% of base voltage^b)	Clearing time (s)	Clearing time: adjustable up to and including (s)		
	V < 45	0.16	0.16		
	45 ≤ V < 60	1	11		
	60 ≤ V < 88	2	21		
	110 < V < 120	1	13		
	V ≥ 120	0.16	0.16		
		Default settings		Ranges of adjustability	
	Function	Frequency (Hz)	Clearing time (s)	Frequency (Hz)	Clearing time (s) adjustable up to and including
UF1	< 57	0.16	56 – 60	10	
UF2	< 59.5	2	56 – 60	300	
OF1	> 60.5	2	60 – 64	300	
OF2	> 62	0.16	60 – 64	10	

3.0 Product Photographs

Photo 1 - Overview of model WVC-300, WVC-350

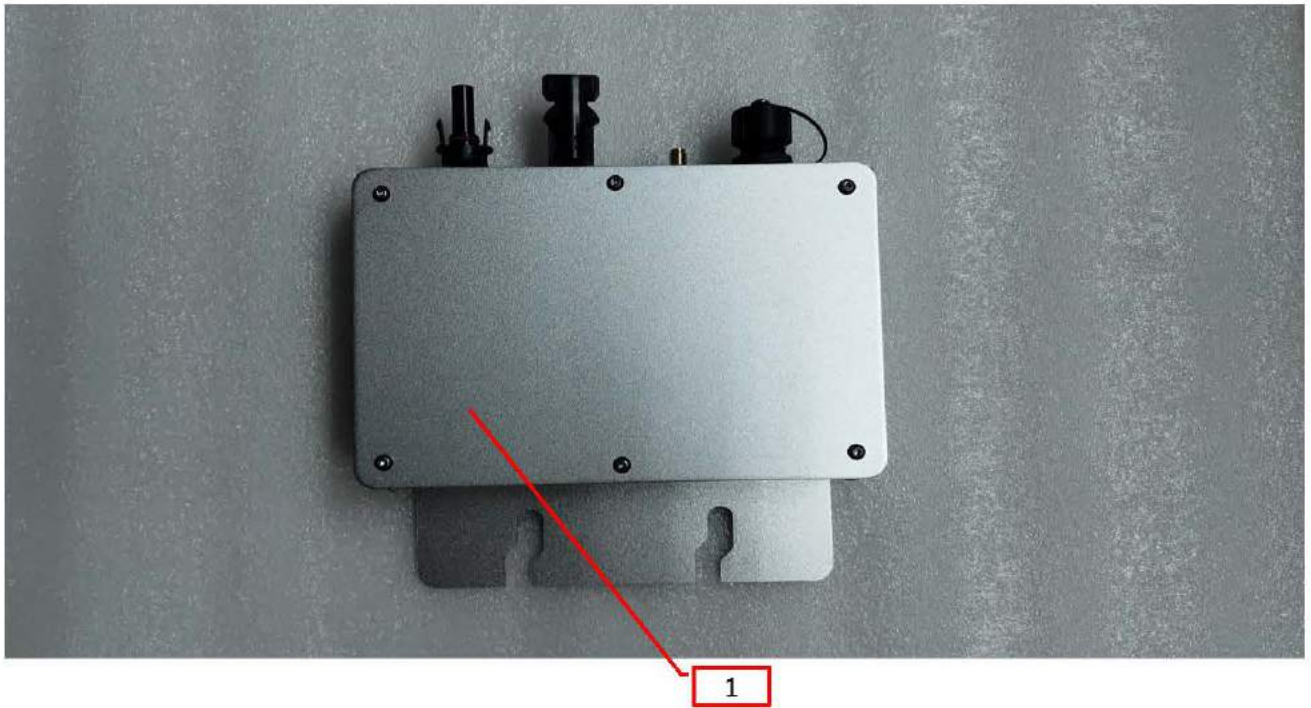

Photo 2 - Bottom view, model WVC-300, WVC-350



3.0 Product Photographs

Photo 3 - View of connection interface, model WVC-300, WVC-350



Photo 4 - Internal view of the unit, model WVC-300, WVC-350

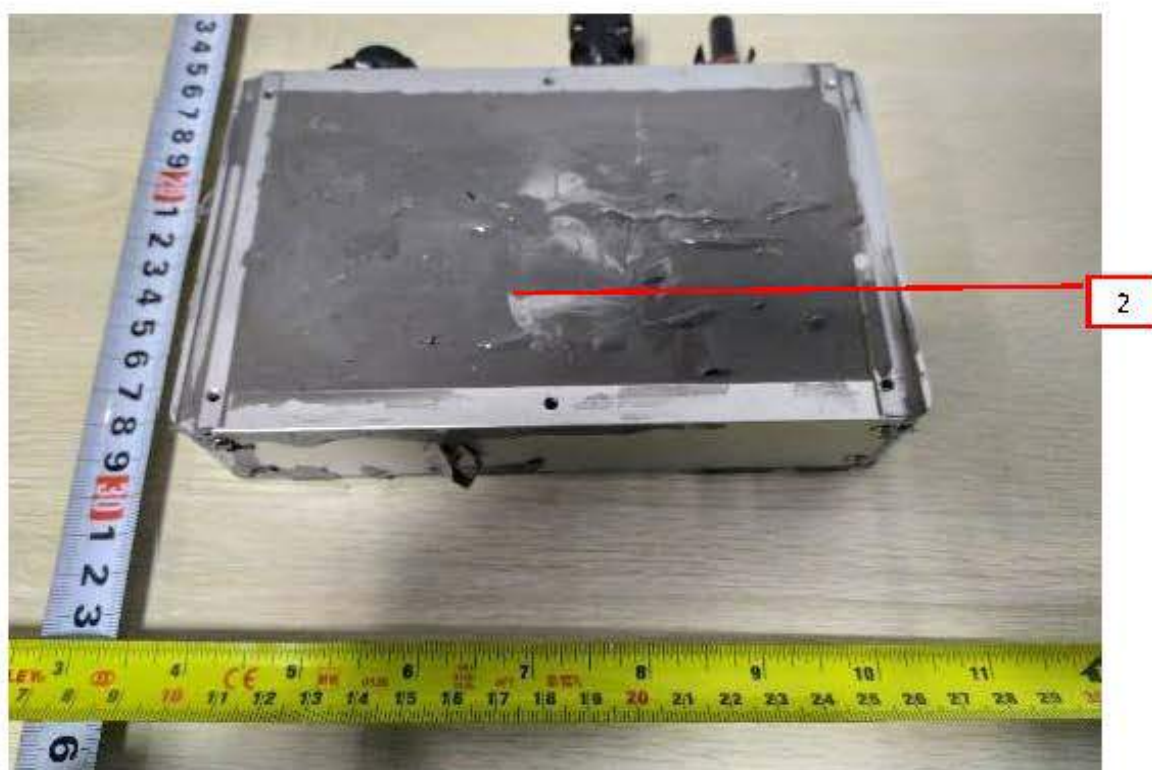

3.0 Product Photographs

Photo 5 - Internal view of the unit (before Pouring sealant),model WVC-300, WVC-350

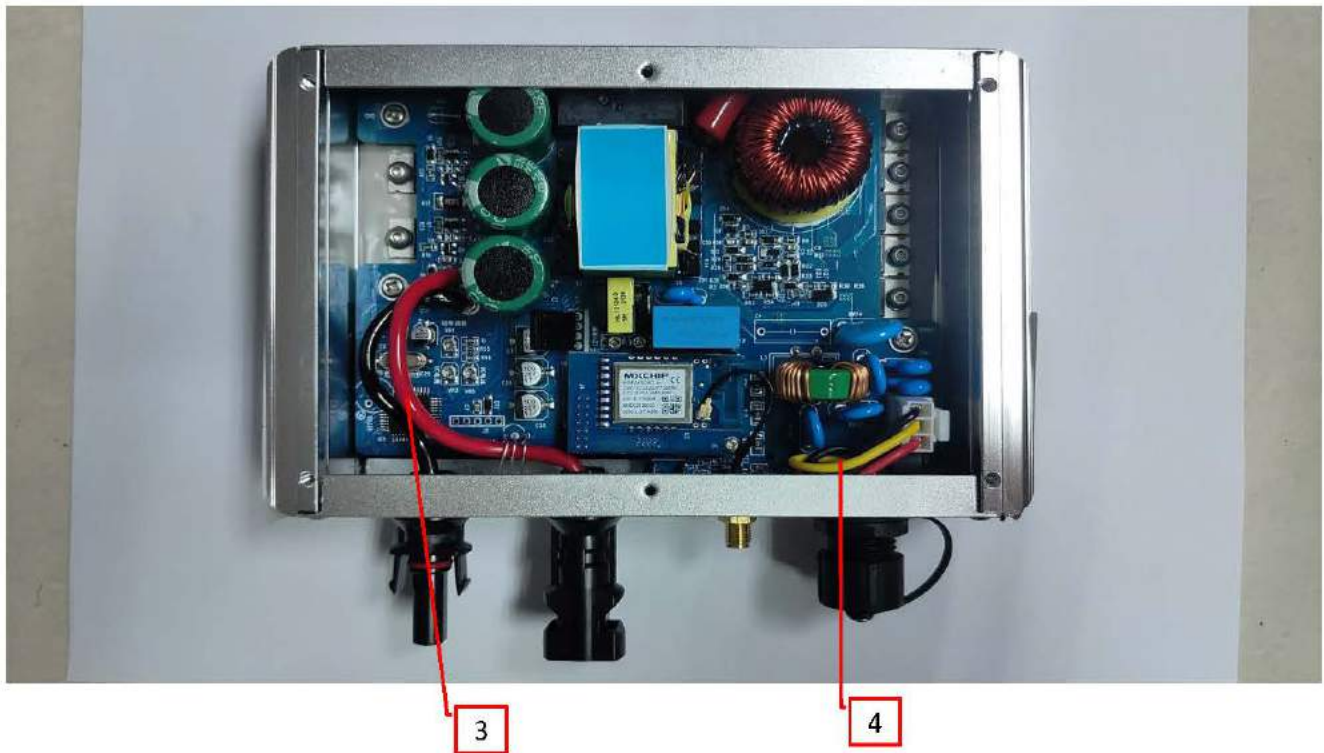

Photo 6 - Internal view of the unit, model WVC-300, WVC-350



3.0 Product Photographs

Photo 7- PCB board view (Components side), model WVC-300, WVC-350

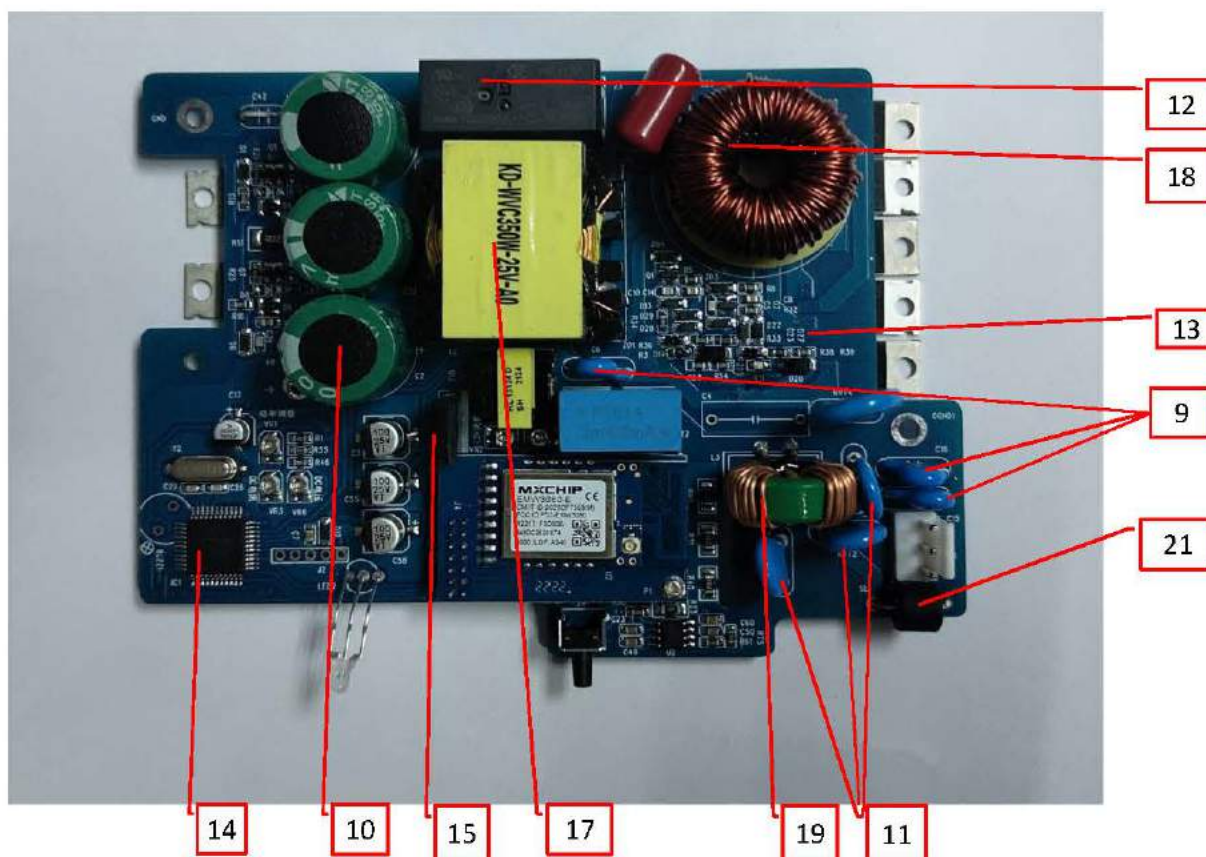
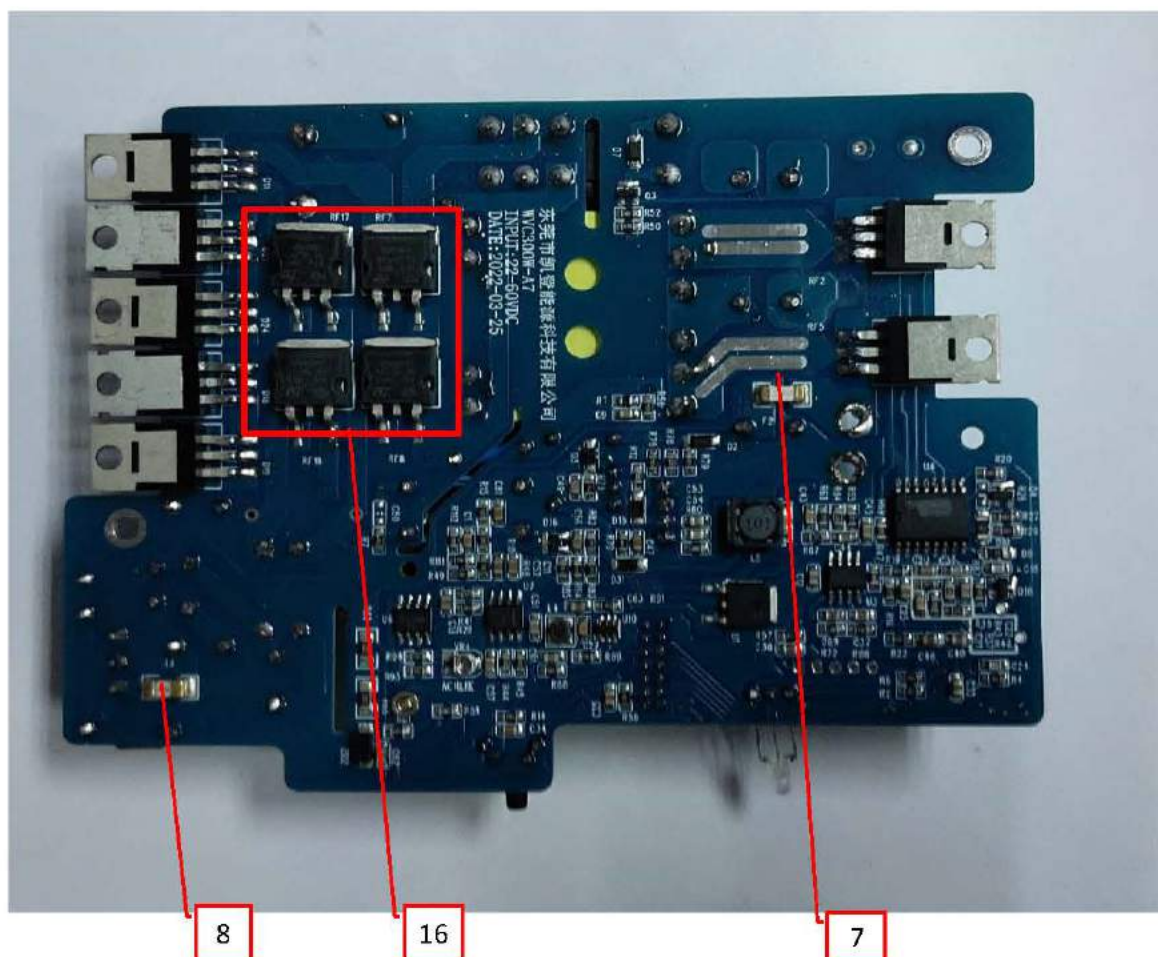

Photo 8- PCB board view (Soldered side), model WVC-300, WVC-350



3.0 Product Photographs

Photo 9- Transformer T2 view



Photo 10- Transformer T2 -inside view



3.0 Product Photographs

Photo 11- Overview of model WVC-600, WVC-700



Photo 12- Side view of model WVC-600, WVC-700



3.0 Product Photographs

Photo 13- Internal view of model WVC-600, WVC-700



Photo 14- Internal view of model WVC-600, WVC-700

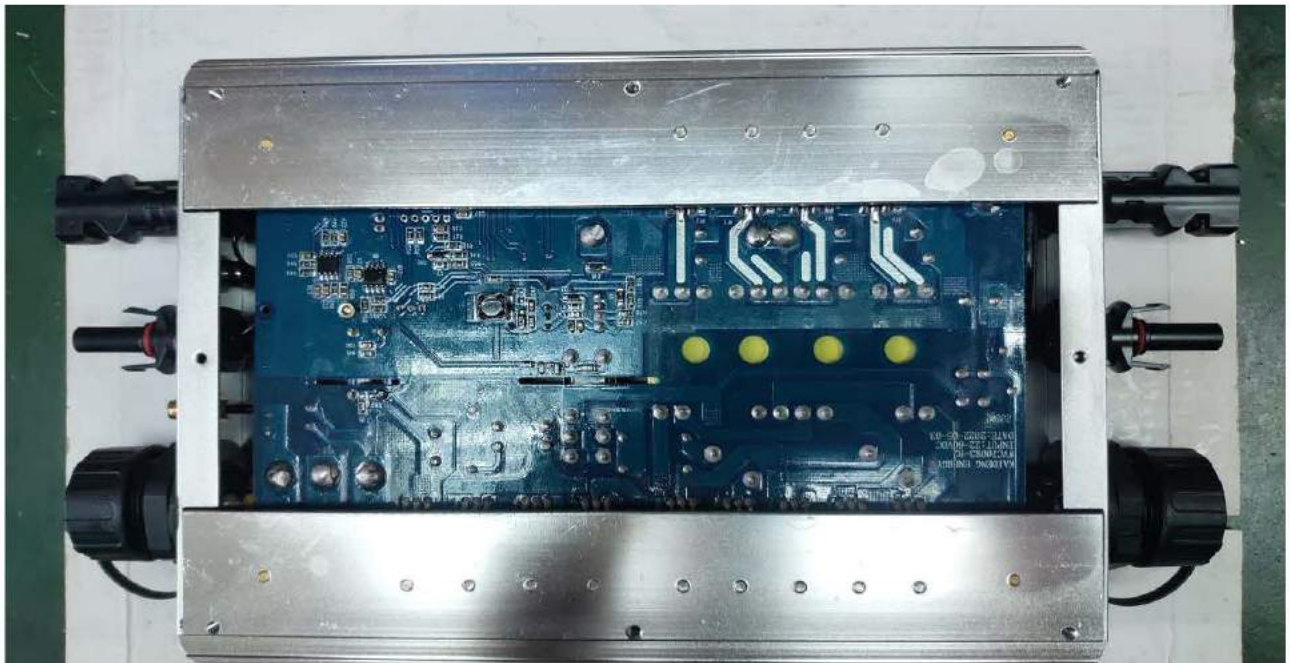

3.0 Product Photographs

Photo 15- Overview of model WVC-1200, WVC-1400



Photo 16- Side view of model WVC-1200, WVC-1400



3.0 Product Photographs

Photo 17- Internal view of model WVC-1200, WVC-1400

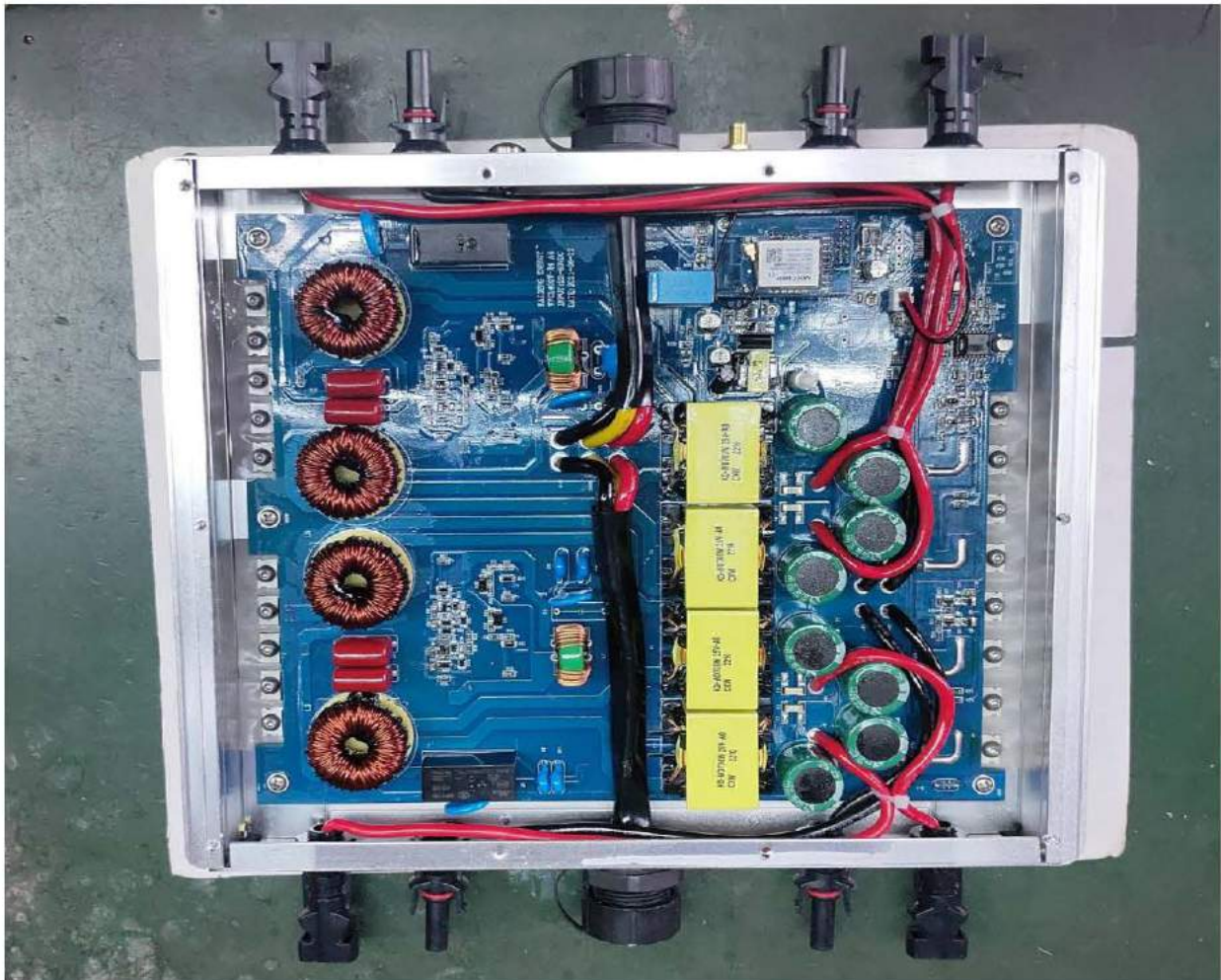

Photo 18- Internal view of model WVC-1200, WVC-1400



4.0 Critical Components						
Photo #	Item no. ¹	Name	Manufacturer/ trademark ²	Type / model ²	Technical data and securement means	Mark(s) of conformity ³
1	1	Enclosure	Dongguan Ganglilong hardware Products Co. LTD	Various	Aluminum alloy 5052	NR
4	2	Pouring sealant	GUANGZHOU HUITIAN NEW MATERIAL CO LTD	5299(#)	V-0, 150°C	cURus
5	3	Internal wiring (DC-in)	Various	1015	600V,105°C, AWG12, VW-1	UR
5	4	Internal wiring (AC-out)	Various	1015	300V,80°C, AWG18, VW-1 for model WVC-300, WVC-350	UR
					600V,105°C, AWG10, VW-1 for model WVC-600, WVC-700, WVC-1200, WVC-1400	
3	5	PV connector	DONGGUAN ZERUN ELECTRONICS TECHNOLOGY Co LTD	Z4S	1500VDC, 30A -40°C ~ 85°C	cURus
3	6	AC connector	SHENZHEN LILUTONG CONNECTOR CORP LTD	LLT-M16	10A, 300V, 3P, Conductor Size AWG 14-18 for model WVC-300, WVC-350	cURus
				LLT-M25	10A, 600V, 3P, Conductor Size AWG 14-18 for model WVC-600, WVC-700	
				LLT-M25	600V,30A, 3P, Conductor Size AWG 8-12 for model WVC-1200, WVC-1400	
8	7	Fuse F2	DONGGUAN REOMAX ELECTRONICS TECHNOLOGY CO LTD	STE	250Vac, 15A	cURus
8	8	Fuse F1	DONGGUAN REOMAX ELECTRONICS TECHNOLOGY CO LTD	STE	250Vac, 6.3A for model WVC-300, WVC-350	cURus
					250Vac, 10A for model WVC-600, WVC-700	
					250Vac, 20A for model WVC-1200, WVC-1400	
7	9	Y capacitor C15,C16,C6	DONG GUAN CITY JIANKUN ELECTRONICS TECHNOLOGY CO LTD	JT	Y1, 2200pF, 400Vac, -25°C ~ -125°C	cURus
			Various	Various		
7	10	Electroanalysis capacitor	Qingsong Aluminum Co., LTD	VENT LOWESR PET	50V, 1500µF, -40~+105°C	NR
7	11	Varistor RVT1,RVT2,RVT3	HONGZHI ENTERPRISES LTD	10D-471K	300VAC, I _{max} :3.5kA 40/85/56	cURus
7	12	Relay Z3	Hongfa electronics co. LTD	JQX-115F012-2ZS4	250VAC, 8A, -40~85°C	cURus

4.0 Critical Components						
Photo #	Item no. ¹	Name	Manufacturer/ trademark ²	Type / model ²	Technical data and securement means	Mark(s) of conformity ³
7	13	PCB	GUANGDONG HETONG TECHNOLOGY CO LTD	FR4	V-0, 130°C	cURus
			Various	Various		
7	14	MCU IC1	Microchip	PIC16F1939	40-pin,28KB Flash,1KB RAM,256B EEPROM	NR
7	15	Optical coupler equipment U9	EVERLIGHT ELECTRONICS CO LTD	EL817C	Cr:8mm,Cl:8mm,insulation voltage:5000V	cURus
8	16	MOSFET RF17,RF7,RF18, RF8	INFINEON	IPB60R099C6	650V,24A, N channel	NR
7	17	Transformer	Dongguan Ling Hong Hung Electronic Technology Co., Ltd.	KD-WVC350W-25V-A0	T2, Class B input: 22~60V,16A output: 325V, 1.6A for model WVC-300, WVC-350 Details see illustration No(s).5 & 5a	NR
				KD-WVC700W-25V-A0	T1,T2,T5,T6, Class B input: 22~60V,16A output: 172V, 1.6A for model WVC-600, WVC-700, WVC-1200 and WVC-1400 Details see illustration No(s).4 & 4a	
7	17a	Bobbin (not shown)	CHANG CHUN PLASTLCS CO.,LTD	T375J	130°C	UR
7	17b	Tape (not shown)	YAHUA ELECTRONIC TECHNOLOGY	CT289	130°C	UR
7	17c	Magnet wire (not shown)	DONG GUAN YIDA INDUSTRIAL CO., LTD	2UEW	155°C	UR
			Various	Various		
7	17d	Tube (not shown)	SHENZHEN WOER HEAT-SHRINKABLE MATERIAL CO LTD	RSFR	600V, 200°C	UR
7	17e	Varnishes (not shown)	HANG CHEUNG COATINGS (HUIYANG) LTD	8562*	155°C	UR
7	18	Chock L2	Dongguan Ling Hong Hung Electronic Technology Co., Ltd.	77930	Class B	NR
7	18a	Magnet Wire (not shown)	TAI-I COPPER(GUANG ZHOU)CO.,LTD	PEW-H	180°C	UR

4.0 Critical Components						
Photo #	Item no. ¹	Name	Manufacturer/ trademark ²	Type / model ²	Technical data and securement means	Mark(s) of conformity ³
7	18b	Varnishes (not shown)	HANG CHEUNG PETROCHEMICAL LTD	8562(a)	155°C,V-0	UR
7	18c	EPOXY (not shown)	LIDUO ELECTRONIC MATERIAL DONGGUAN CO.,LTD	E-500	130°C, V-0	UR
7	19	Common inductors L3	Dongguan Ling Hong Hung Electronic Technology Co., Ltd.	1807	Class B	NR
7	19a	Magnet Wire (not shown)	TAI-I COPPER(GUANGZHOU)CO.,LTD	2UEW-B	155°C	UR
7	19b	Tube (not shown)	SHENZHEN WOER HEAT-SHRINKABLE MATERIAL CO LTD	RSFR	600V, 200°C	UR
5	20	Plastic	DONGGUAN NEW-ORIENT TECHNOLOGY CO LTD	ZY9150	Silicone Molding Resin (SIR), furnished as paste. 150°C	cURus
7	21	Discharge tube SL1	Shenzhen Shaoxin Electronic Co. Ltd	SE8A-600X	600V, I _{max} :25KA	cURus
1	22	Label (not show)	AVERY (CHINA) CO LTD	PET TC/S333	-40 to 150 degC, Outdoor Use	UR
			Various	Various		

NOTES:

- 1) Not all item numbers are indicated (called out) in the photos, as their location is obvious.
- 2) "Various" means any type, from any manufacturer that complies with the "Technical data and securement means" and meets the "Mark(s) of conformity" can be used.
- 3) Indicates specific marks to be verified, which assures the agreed level of surveillance for the component. "NR" - indicates Unlisted and only visual examination is necessary. "See 5.0" indicates Unlisted components or assemblies to be evaluated periodically refer to section 5.0 for details.

5.0 Critical Unlisted CEC Components

No Unlisted CEC components are used in this report.

6.0 Critical Features

Recognized Component - A component part, which has been previously evaluated by an accredited certification body with restrictions and must be evaluated as part of the basic product considering the restrictions as specified by the Conditions of Acceptability.

Listed Component - A component part, which has been previously Listed or Certified by an accredited Certification Organization with no restrictions and is used in the intended application within its ratings.

Unlisted Component - A part that has not been previously evaluated to the appropriate designated component standard. It may also be a Listed or Recognized component that is being used outside of its evaluated Listing or component recognition.

Critical Features/Components - An essential part, material, subassembly, system, software, or accessory of a product that has a direct bearing on the product's conformance to applicable requirements of the product standard.

Construction Details - For specific construction details, reference should be made to the photographs and descriptions. All dimensions are approximate unless specified as exact or within a tolerance. In addition to the specific construction details described in this Report, the following general requirements also apply.

1. Spacing -

- 1) Between Live parts to earth, the min. spacing through air must not less than 0.1mm (DC sides), 3.0mm(AC sides). The min spacing over surface must not less than 0.1mm (DC sides), 3.0mm(AC sides)
- 2) Between primary winding and Secondary winding of isolated transformer, the min. spacing through air must not less than 3.0mm. The min spacing over surface must not less than 3.0mm.

2. Mechanical Assembly - Components such as switches, fuseholders, connectors, wiring terminals and display lamps are mounted and prevented from shifting or rotating by the use of lockwashers, starwashers, or other mounting format that prevents turning of the component.

3. Corrosion Protection - All ferrous metal parts are protected against corrosion by aluminum alloy or the equivalent.

4. Accessibility of Live Parts - All uninsulated live parts in primary circuitry are housed within a metal enclosure constructed with no openings other than those specifically described in Sections 4 and 5.

5. Grounding - All exposed dead-metal parts and all dead-metal parts within the enclosure that are exposed are connected to the the equipment grounding terminal, details as photos view.

6. Polarized Connection - This product is provided with a polarized power supply connection. All fuses are connected only to the ungrounded supply circuit conductor.

7. Internal Wiring - Internal wiring is routed away from sharp or moving parts. Internal wiring leads terminating in soldered connections are made mechanically secure prior to soldering. Recognized Component separable (quick disconnect) connectors of the positive detent type, closed loop connectors, or other types specifically described in the text of this report are also acceptable as internal wiring terminals. At points where internal wiring passes through metal walls or partitions, the wiring insulation is protected against abrasion or damage by plastic bushings or grommets. Input wiring and output wiring is minimum 10 AWG, with a minimum rating of 600V, 105°C

8. Schematics - Refer to Illustration No. 2 for schematics requiring verification during Field Representative Inspection Audits.

9. Markings - The product is marked as follows: Applicant's name, brand name, model number, date of manufacturer, complete electrical rating as required by applicable standards.

10. Cautionary Markings - The following are required: Refer to Illustration No. 1 for details

11. Installation, Operating and Safety Instructions - Instructions for installation and use of this product are provided by the manufacturer. Refer to Illustration No.3 & 3a-3i for details.

12. Transformer - Supplier records must be provided that indicate the received shipment of transformers (section 4.0, item 17) were constructed as indicated in Illustration No(s). 4 to 4a & 5 to 5a. These records must be available at the factory for inspection on every received shipment.

7.0 Illustrations

Illustration 1 - Marking

CAUTION!

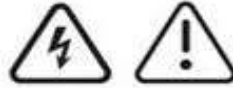

- Risk of electric shock Normally grounded conductors may be ungrounded and energized when a ground-fault is indicated.
- Do not remove cover or user serviceable parts inside. Refer servicing to qualified service personnel.
- Both AC and DC voltage sources are terminated inside this equipment. Each circuit must be individually disconnected before servicing.
- When the photovoltaic array is exposed to light, it supplies a DC voltage to this equipment
- To be connected only to a dedicated branch circuit. Maximum branch circuit over current protection: 35A

ATTENTION!

- Risque de choc électrique Les conducteurs normalement mis à la terre peuvent être non mis à la terre et alimentés lorsqu'un défaut à la terre est indiqué.
- Ne retirez pas le couvercle des pièces réparables par l'utilisateur à l'intérieur. Référez-vous à un technicien qualifié.
- Les deux sources de tension CA et CC sont terminées à l'intérieur de cet équipement. Chaque circuit doit être déconnecté individuellement avant l'entretien.
- Lorsque le champ photovoltaïque est exposé à la lumière, il fournit un DC voltage à cet équipement
- Pour être connecté uniquement à un circuit de dérivation dédié. Circuit de dérivation Maximum contre la protection de courant: 35A

7.0 Illustrations

Illustration 2 - Circuit diagram

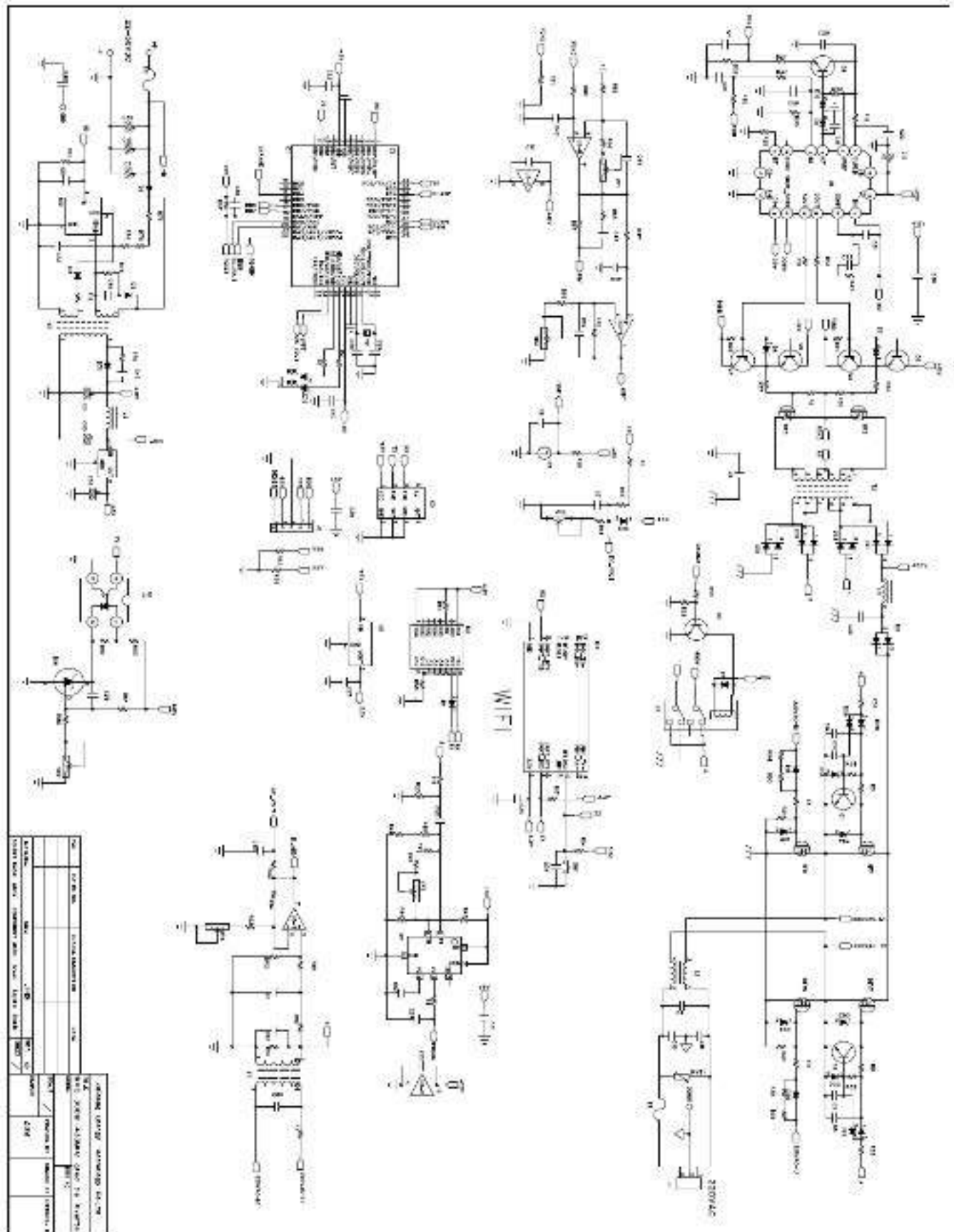

7.0 Illustrations

Illustration 3- User manual

Important Safety Information

Please read this manual first.

This manual contains important instructions that should be followed when installing and maintaining Microinverters.

In order to reduce the risk of electric shock and to ensure the safe installation and operation of Microinverters, the following safety symbols are always present in this document to indicate dangerous situations and important safety instructions.



WARNING: This indicates a situation where failure to follow instructions may be a safety hazard or cause equipment malfunction. Use extreme caution and follow instructions carefully.



NOTE: This indicates information particularly important for optimal system operation. Follow instructions closely.

Safety Instructions



WARNING: Be aware that the body of the Microinverters is the heat sink and can reach a temperature of 80°F under extreme conditions. To reduce risk of burns, do not touch.





- Perform all electrical installations in accordance with all local electrical codes and the National Electrical Code (NEC), ANSI/NFPA 70.
- Be aware that only qualified personnel should install and/or replace Microinverters.
- Do not attempt to repair the Microinverter; it contains no user-serviceable parts. If it fails, please contact customer service to obtain an ID number and start the replacement process. Tampering with or opening the Microinverter will void the warranty.
- Before installing or using the cautionary markings in the technical description and on the Microinverter system and the PV-array.
- Connect the Microinverter to the electrical utility grid only after receiving prior approval from the utility company.
- Do NOT disconnect the PV module from the Microinverter before removing AC power.

7.0 Illustrations

Illustration 3a - User manual

Microinverter Installation

Follow the instructions in this section to install Microinverters.

-  **WARNING** : Before installing the Microinverter, read all instructions and cautionary markings in the user manual, on the Microinverter, and on the photovoltaic array
-  **WARNING** : Perform all electrical installations in accordance with all local electrical codes and the National Electrical Code (NEC), ANSI/NFPA 70, in US or the Canadian Electrical Code (CEC) in Canada.
-  **WARNING** : Connect the Microinverter to the electrical utility grid only after receiving prior approval from the utility company.
-  **WARNING** : Be aware that only qualified personnel should connect the Microinverter to the electrical utility grid.
-  **WARNING** : Be aware that installation of this equipment includes risk of electric shock. Normally grounded conductors may be ungrounded and energized when a ground fault is indicated.

Installation Procedure

Installing the Microinverter System involves several key steps:

1. Measuring service and Installing the AC branch circuit junction box
2. Attaching the Microinverters to the racking
3. Connecting the Microinverter wiring harnesses
4. Grounding the system
5. Completing the installation map and Connecting the PV modules

Each of the detailed installation steps in the following sections is numerically referenced in the installation diagram below.

-  **WARNING** : DO NOT connect Microinverters to the utility grid or energize the AC circuit(s) until you have completed all of the installation procedures as described in the following sections.

7.0 Illustrations

Illustration 3b - User manual

Our Micro Inverter System is the most technologically advanced inverter system in the world. The system is widely used in utilities and households. This manual details the safe installation and operation of Kaideng Micro inverters.

Three key components of Kadant Micro Inverter System:

- the Micro Inverter
- the Wi-Fi modem (Data collector)
- the Mobile App

This system maximizes energy collection efficiency, improves system reliability, and simplifies design, installation, and management.

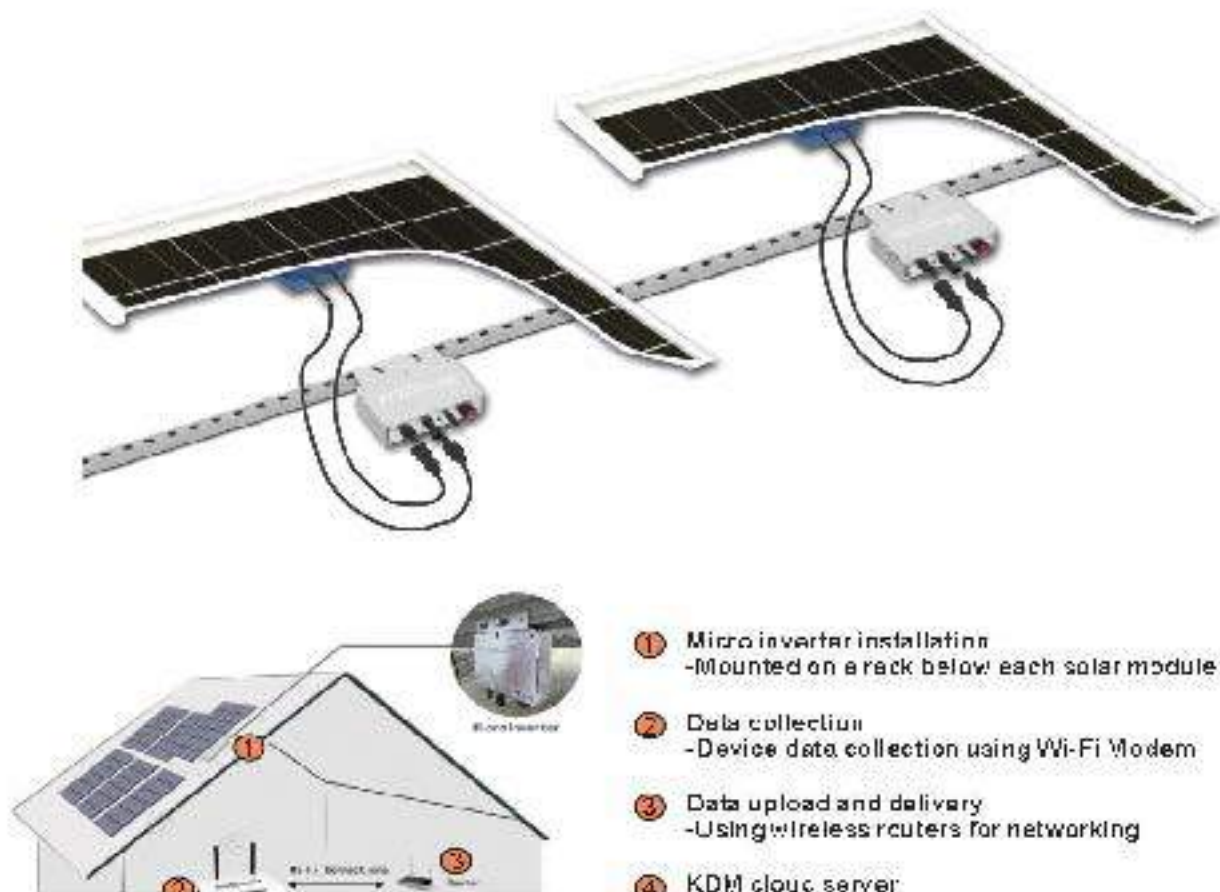

7.0 Illustrations

Illustration 30- User manual

Port diagram



① Solar PV Input

② Solar PV Input

③ AC Output

④ WiFi/433 Antenna

⑤ LED Display

WARNING: Please connect the inverter by the instruction manual. If have any question please contact with relative persons.

WARNING: Non-professionals do not disassemble. Only qualified person can repair the product.

WARNING: Please install inverter in the low humidity and well ventilated place to avoid the inverter over-heating, and clear around the inflammable and explosive materials.

WARNING: When using the product, avoid children touching, playing, to avoid electric shock.

WARNING: Only Connected solar panels.

NOTE: LED Display

1. Red light 3 second---when the red light is on for 3 seconds, the equipment enters the normal working state.
2. Green flash fast---MPPT searching;
3. Green flash slow---MPPT + power fine-tuning;
4. Red flash slow---MPPT - power fine-tuning;
5. Green lights on 3s and off 0.5s---MPPT locked;
6. Red light steady---a. Islanding protection; b. Over-temperature protection; c. Over / low AC voltage protection; d. Over / low DC voltage protection; e. Fault

Remarks:

LED flashing in the process of being working condition: inverters connected to AC & DC sides→Red light 3 second→Green light flash fast(MPPT searching);→Green light flash slow(MPPT + power fine-tuning) / Red light flash slow(MPPT - power fine-tuning); / green lights on 3s and off 0.5s (MPPT locked)

7.0 Illustrations

Illustration 3d- User manual

4. Trial run and operation test

- 1 Check that all equipment and lines in the system are properly installed and connected;
- 2 Check whether all switches in the system are already open;
- 3 Close the switches of each branch to power on and check whether all the micro inverters in each branch are working normally. If there is an abnormality, please check the corresponding phenomenon according to the "Exception Checklist" to determine the cause of the abnormality;
- 4 After each branch is inspected, close all branch switches on sunny days and when the sun is most intense, and let the entire power generation system work. Check again that all inverters are working properly, and then check whether the voltage at the end of each branch is normal. The terminal voltage cannot exceed 250V (the optimal voltage is 240V). If the terminal voltage exceeds 250V, it indicates that the load capacity of the AC bus of the system is insufficient and the line needs to be rectified in time;

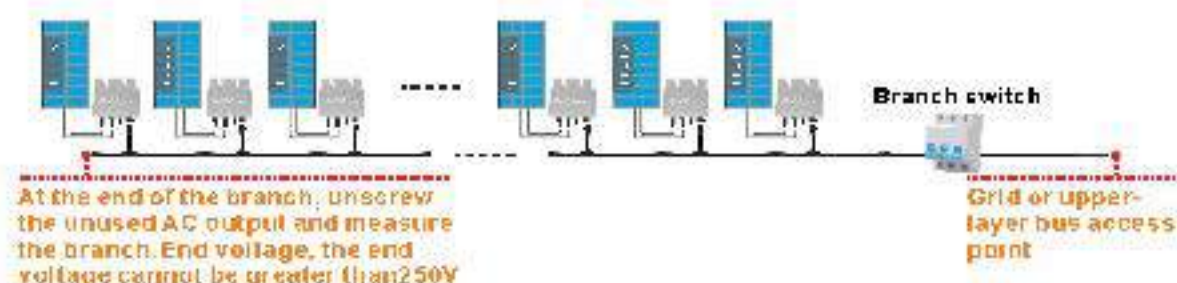

- 5 Check whether the power factor of the entire system during normal operation is greater than 97%. If it is less than 97%, you need to check and analyze the power of each branch. At the same time, please check whether the open-circuit voltage VOC of the photovoltaic module meets the standard and whether the AC output voltage of the micro inverter is consistent. The installed grid environment matches;
- 6 All micro-inverters can detect the surface temperature of the inverter after waiting for 1 hour during normal operation. If the surface temperature of the inverter exceeds 80°C, please check whether the AC output voltage of the inverter matches the grid environment;
- 7 When the micro-inverter is operating normally when the sun is the strongest, check whether the output power of the entire system is consistent with the installed capacity. If it does not, please check the corresponding phenomenon according to the "exception checklist" to determine the abnormal cause;
- 8 After all the tests are completed and there are no abnormalities, it can be officially connected to the network;

7.0 Illustrations

Illustration 3e- User manual

Installation Of Micro Inverter

Step 1

Installation for fixed the inverter on the PV holder with the screws attached to it as following:

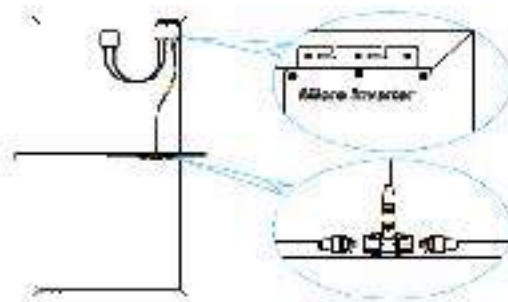

Step 2

Connect the two DC terminal of the PV to the inverter, positive to positive, negative to negative. Show below:

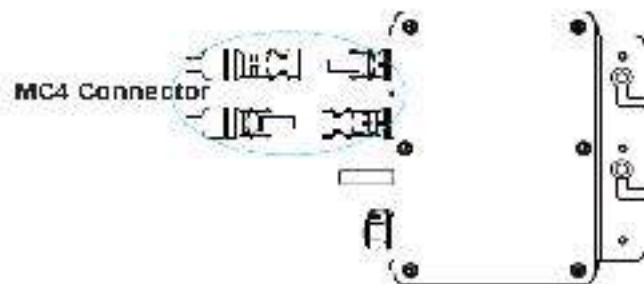

Step 3

Open the waterproof cap on AC output side of the micro inverter, then plug to AC power line. Show below:

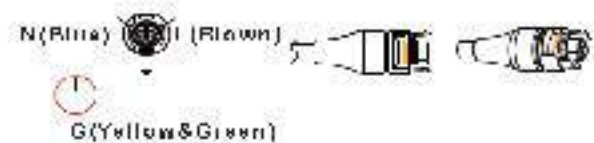
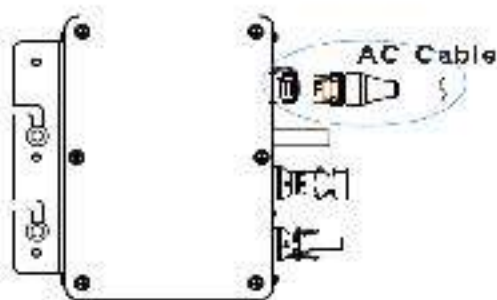

Step 4

Plug the AC output line to main AC cable:

Step 5

Repeat the first step to the third step to complete the installation of micro Inverters;

Step 6

Finally, please connect the AC main cable to the utility grid to run renewable energy and saving \$\$\$!

System composition



7.0 Illustrations

Illustration 3f- User manual

Micro Inverter WYC-350 Installation Guide

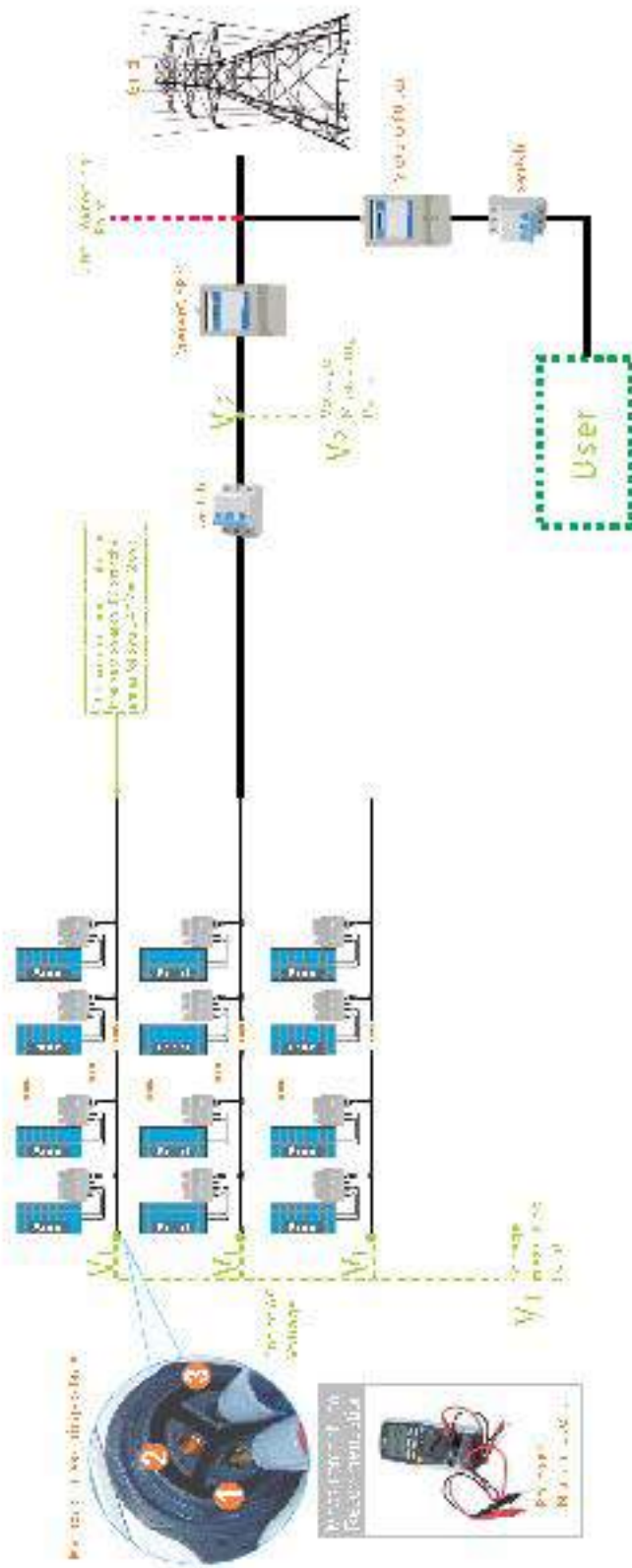

- ① After the solar power generation system is installed correctly, do the following test preparation work before the AC power up:
 1. Please check whether all the plug connected well, whether there is loose connected;
 2. Measure all L-N, N-G, N-G of each branch. In order to no short circuit, if there is a short circuit, please correct;
 3. Complete the above preparation work and prepare the test run;
- ② At the time of test run, please select noon and the sunshine is the most strong time of the local time;
- ③ To connect AC power to see if each inverter is on the green light or test flashing;
- ④ Please measure each branch's AC voltage of the AC end point V1 (as shown in figure) at the system full load output (Max. output);
- ⑤ Please measure AC voltage of the grid-connecting point V2 (as shown in figure) at the system full load output (Max. output);
- ⑥ The voltage difference between V1 and V2 must be less than 5V, if more than 5V then the load capacity of the main branch cable is not enough;
- ⑦ Please ensure that the grid-connecting point voltage V2 is in the this range: 130V~252V;
- ⑧ **Strictly unplug the inverter connector with electricity, power grid MUST be cut off while unplugging.**

7.0 Illustrations

Illustration 3g- User manual

Sample Wiring Diagram WVC-350 Single Phase

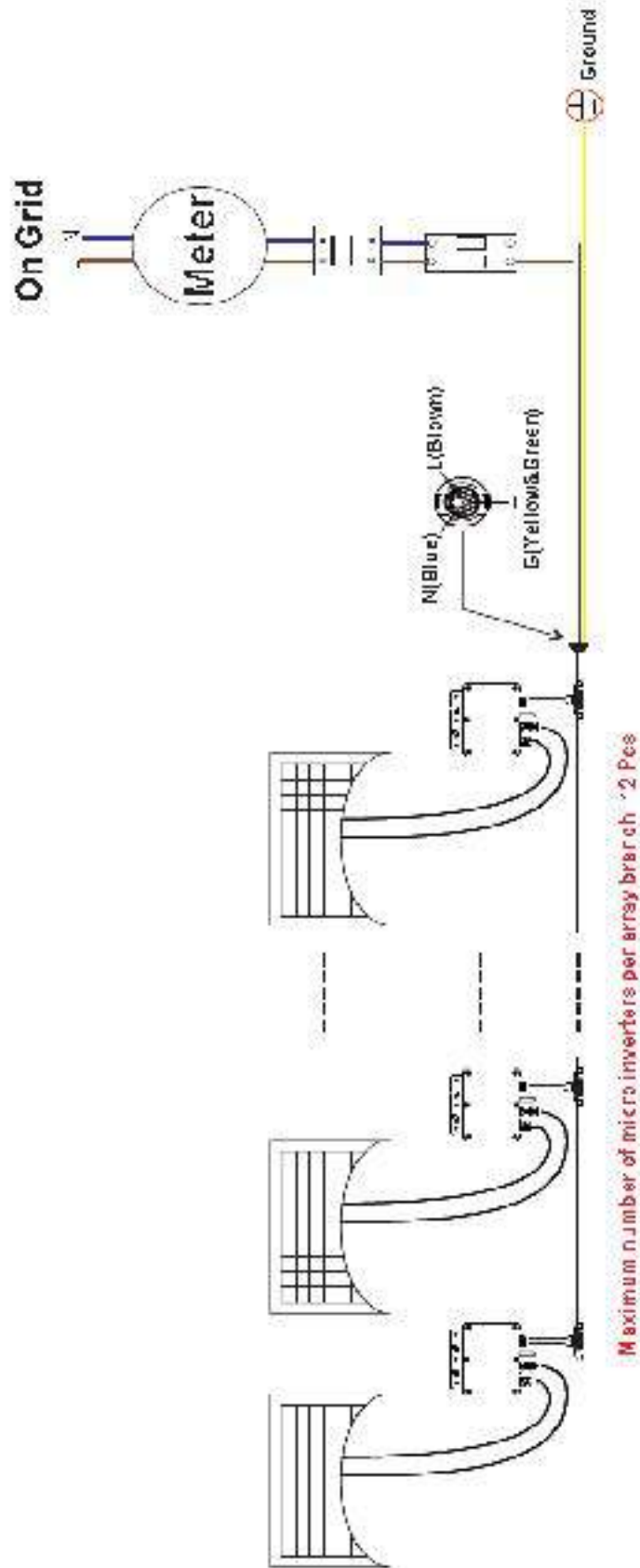

7.0 Illustrations

Illustration 3h- User manual

Sample Wiring Diagram WVC-350 Dual Phase

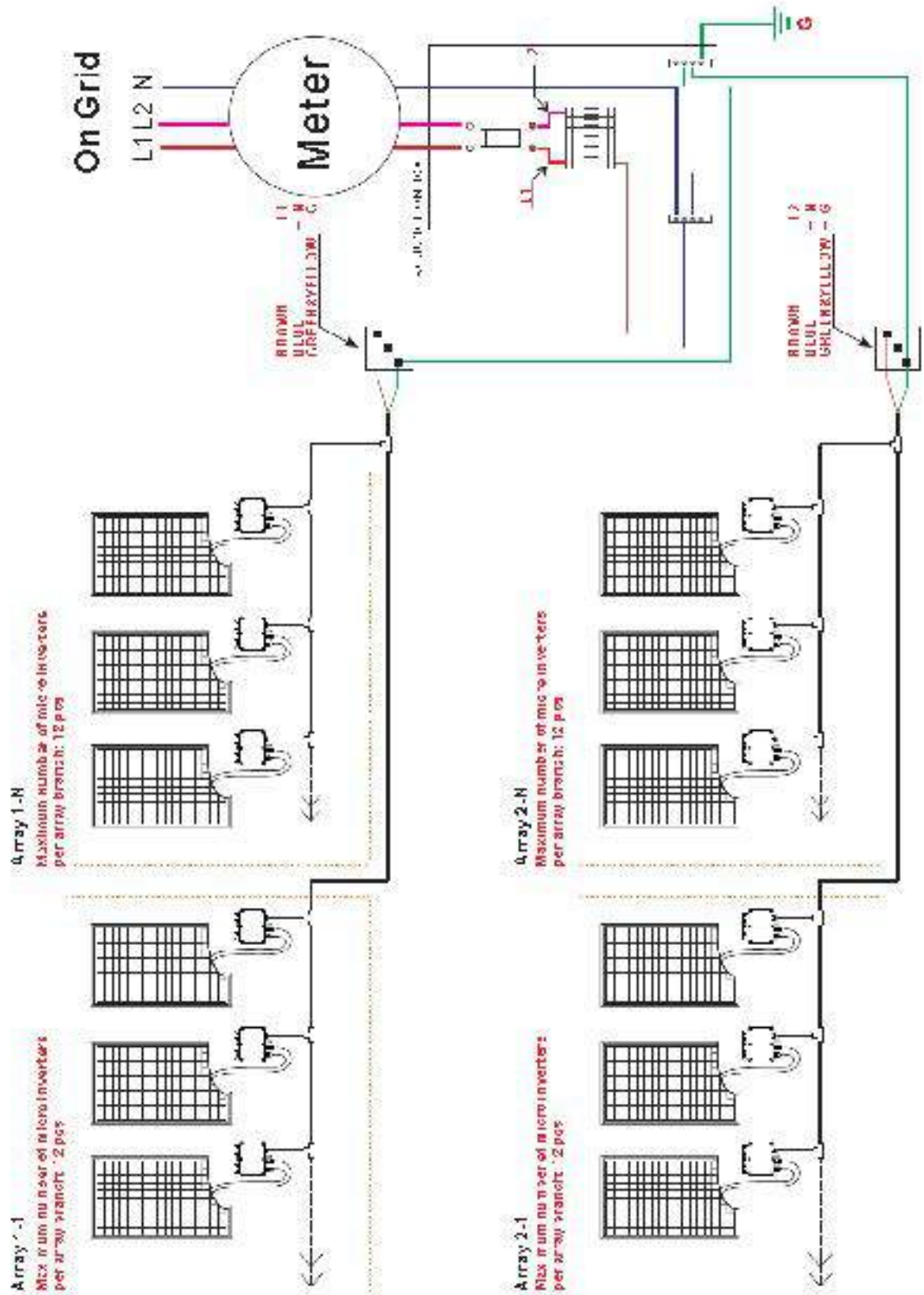

7.0 Illustrations

Illustration 3- User manual

Sample Wiring Diagram WVC-350 Triple Phase

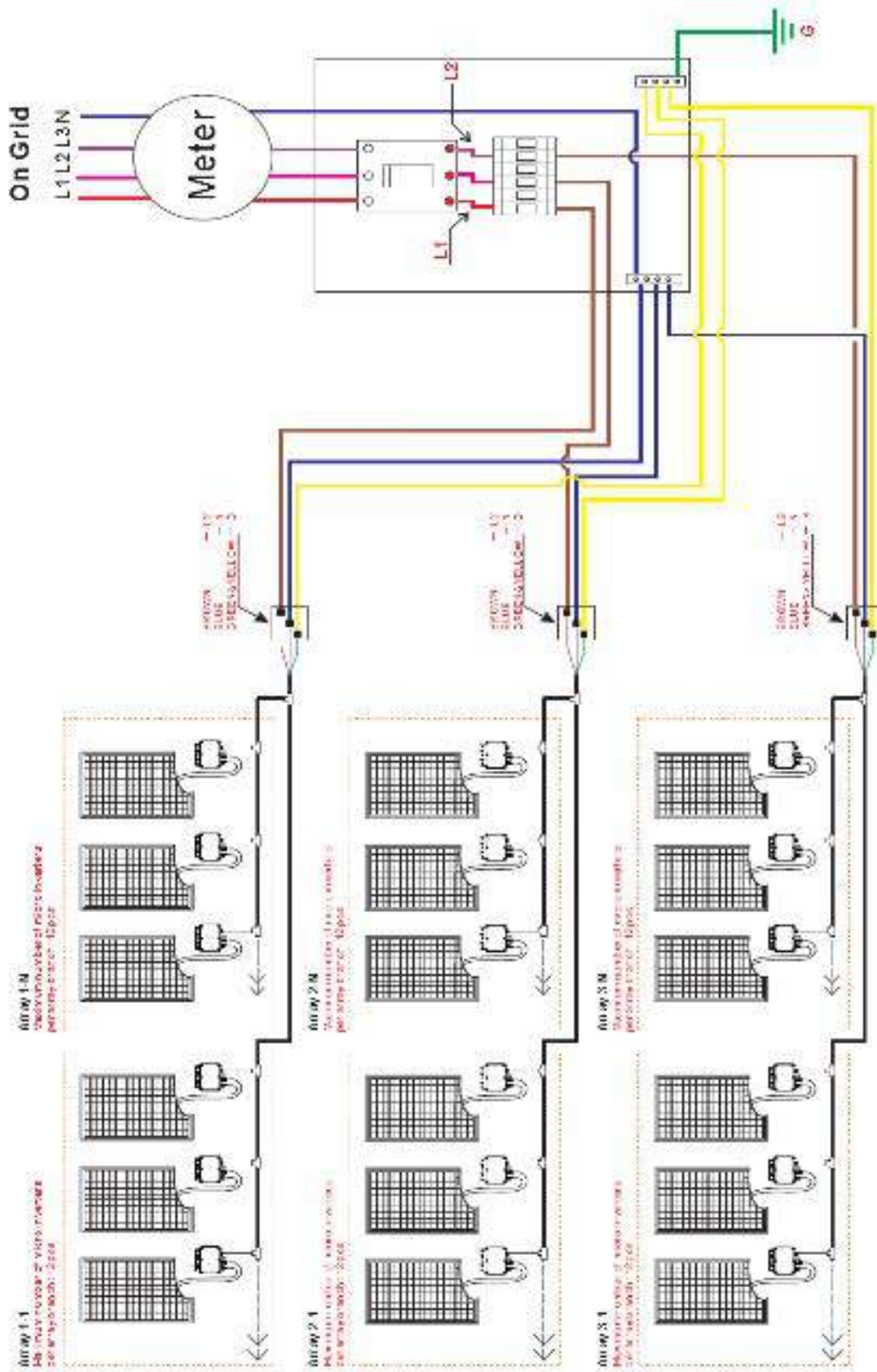

7.0 Illustrations

Illustration 4- Specification for transformer for model WVC-600, WVC-700, WVC-1200 and WVC-1400

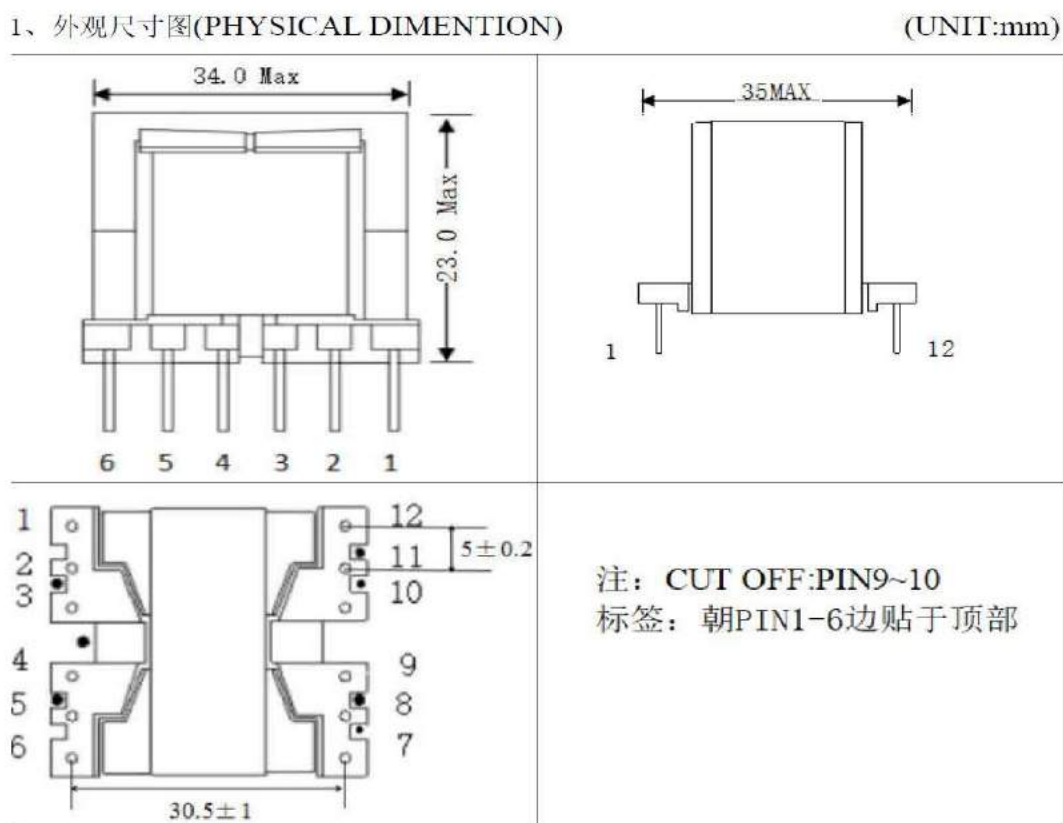
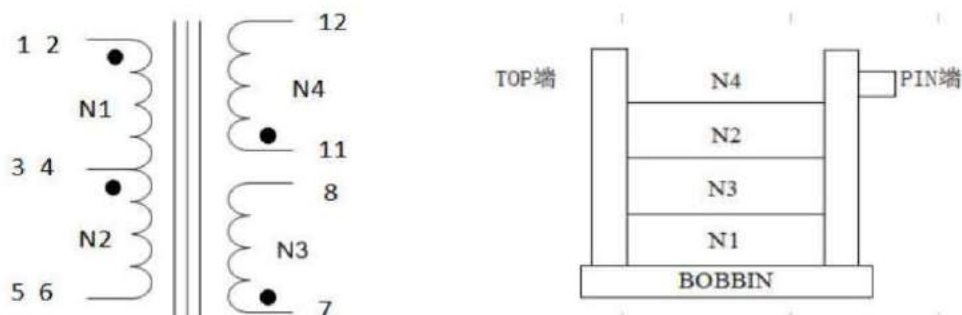

Illustration 4a- Specification for transformer

2、绕制工艺图(WINDING INSTRUCTIONS VIEW)

绕组 No.	起端 Start	回端 Finish	线径 Wire Size	圈数 Turns	绕制方式 Way And Wind	挡墙	胶带圈数 Tape And Turns
N1	1, 2	3	2UEW Ø0.5×4P	4TS	密绕		3TS
N3	7	8	2UEW Ø0.55×2P	14TS	密绕		3TS
N2	4	5, 6	2UEW Ø0.5×4P	4TS	密绕		3TS
N4	11	12	2UEW Ø0.55×2P	14TS	密绕		3TS

3、电路原理图(SCHEMATIC DIAGRAM) 4、绕制示意图(WINDING SECTIONAL VIEW)



7.0 Illustrations

Illustration 5- Specification for transformer for model WVC-300, WVC-350

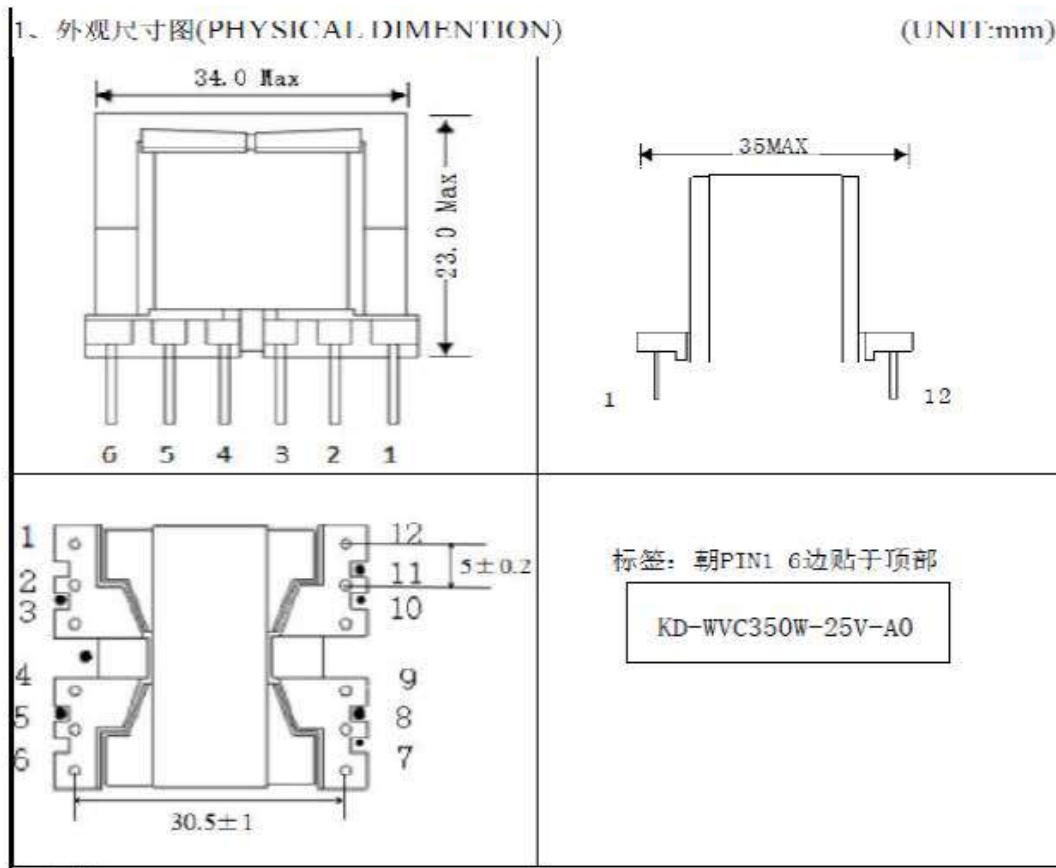
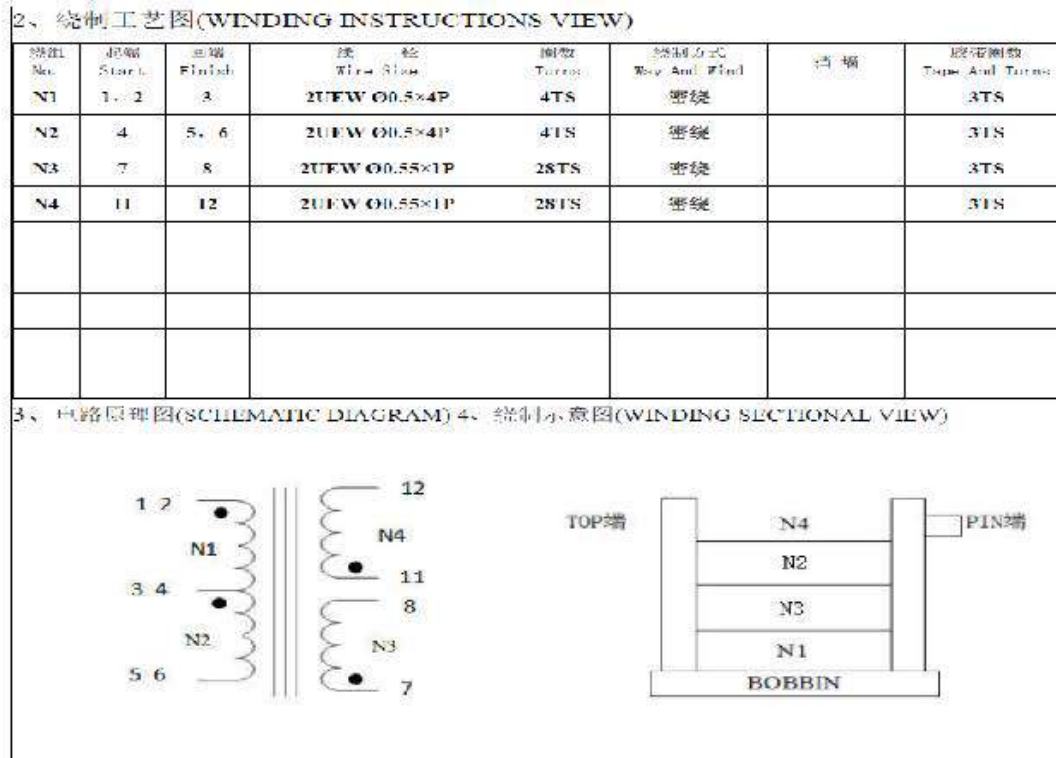

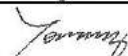

Illustration 5a- Specification for transformer



8.0 Test Summary			
Evaluation Period	20-Nov-2019 - 11-Nov-2021		Project No. 191120006GZU
Sample Rec. Date	20-Nov-2019	Condition Prototype	Sample ID. S191120006-001~010
Test Location	Intertek Testing Services Shenzhen Ltd. Guangzhou Branch Room 02, &101/E201/E301/E401/E501/E601/E701/E801 of Room 01 1-8/F., No. 7-2, Caipin Road, Science City, GETDD Guangzhou, Guangdong, China		
Test Procedure	Testing Lab		
Determination of the result includes consideration of measurement uncertainty from the test equipment and methods. The product was tested as indicated below with results in conformance to the relevant test criteria.			
The following tests were performed:			
Test Description	UL 1741:2010 Ed.2+R:16Sep20 20, Clause	CSA C22.2#107.1:2 016 Ed.4, Clause	IEEE 1547:2003, IEEE1547a:2014, IEEE 1547.1:2005 Clause
Maximum Voltage Measurements	42	6.1.2	--
Temperature	43	6.3	--
Dielectric Voltage-Withstand Test	44	6.5	--
Output Power Characteristics-Output Ratings	45.2	10.5.1	--
Output Power Characteristics-DC Input Range	45.3	6.2	--
Abnormal Tests: Output overload test	47.2	6.7	--
Abnormal Tests: Short-circuit test	47.3	6.6.1 a)	--
Abnormal Tests: DC input mis-wiring test	47.4	13.4.2	--
Abnormal Tests: Ventilation test	47.5	6.6.1 b) & c)	--
Abnormal Tests: Component Short & open circuit	47.6	6.6.7	--
Utility Compatibility: Loss of Control Circuit	47.8	14.3.6	--
Grounding Impedance	48	--	--
Capacitor voltage Determination test	57	6.19	--
Static Load	59	6.22	--
Compression test	60	6.9	--
Securement of components	--	6.16	--
Rain and Sprinkler Tests	61	--	--
Operational Temperature test	--	--	5.1.2.1
Storage Temperature test	--	--	5.1.2.2
Test for Over-voltage - Magnitude	--	14.3.4	5.2.1.2
Test for Over-voltage – Trip time	--	14.3.4	5.2.1.3
Test for Under-voltage - Magnitude	--	14.3.4	5.2.2.2
Test for Under-voltage – Trip time	--	14.3.4	5.2.2.3
Test for Over-frequency - Magnitude	--	14.3.4	5.3.1.2
Test for Over-frequency – Trip time	--	14.3.4	5.3.1.3
Test for Under-frequency - Magnitude	--	14.3.4	5.3.2.2
Test for Under-frequency – Trip time	--	14.3.4	5.3.2.3
Start up current measurement (method 2)	--	--	5.4.4
Interconnect integrity:- Protection from EMI test	--	--	5.5.1
Interconnect integrity: - Surge Withstand test	--	--	5.5.2
Dielectric test for paralleling devices	--	--	5.5.3
Unintentional islanding	--	14.3.5	5.7.1
Open phase	--	--	5.9
Reconnect following abnormal condition disconnect	--	--	5.10
Harmonics	--	14.3.3	5.11

8.1 Signatures			
A representative sample of the product covered by this report has been evaluated and found to comply with the applicable requirements of the standards indicated in Section 1.0.			
Completed by:	Jason Fu	Reviewed by:	Tommy Zhong
Title:	Supervisor	Title:	Technical Manager
Signature:		Signature:	

9.0 Correlation Page For Multiple Listings

The following products, which are identical to those identified in this report except for model number and Listee name, are authorized to bear the ETL label under provisions of the Intertek Multiple Listing Program.

BASIC LISTEE	Dongguan Kaideng Energy Technology Co., Ltd
Address	4th Floor, Fuyuan Commercial Building, No.1, Lane 13, Maiyuan Road, Xin'an Community Chang'an Town, DONGGUAN CITY, Guangdong
Country	CHINA
Product	Utility-Interactive Micro Inverter

MULTIPLE LISTEE 1	None
Address	
Country	
Brand Name	

ASSOCIATED MANUFACTURER	
Address	
Country	

MULTIPLE LISTEE 1 MODELS	BASIC LISTEE MODELS

MULTIPLE LISTEE 2	None
Address	
Country	
Brand Name	

ASSOCIATED MANUFACTURER	
Address	
Country	

MULTIPLE LISTEE 2 MODELS	BASIC LISTEE MODELS

MULTIPLE LISTEE 3	None
Address	
Country	
Brand Name	

ASSOCIATED MANUFACTURER	
Address	
Country	

MULTIPLE LISTEE 3 MODELS	BASIC LISTEE MODELS

10.0 General Information

The Applicant and Manufacturer have agreed to produce, test and label ETL Listed products in accordance with the requirements of this Report. The Manufacturer has also agreed to notify Intertek and to request authorization prior to using alternate parts, components or materials.

COMPONENTS

Components used shall be those itemized in this Intertek report covering the product, including any amendments and/or revisions.

LISTING MARK

The ETL Listing mark applied to the products shall either be separable in form, such as labels purchased from Intertek, or on a product nameplate or other media only as specifically authorized by Intertek. Use of the mark is subject to the control of Intertek.

The mark must include the following four items:

- 1) applicable country identifiers "US" and/or "C" or "US", "C" and "EU"
- 2) the word "Listed" or "Classified" or "Recognized Component" (whichever is appropriate)
- 3) a control number issued by Intertek
- 4) a product descriptor that identifies the standards used for certification. Example:

For US standards, the words, "Conforms to" shall appear with the standard number along with the word, "Standard" or "Std." Example: "Conforms to ANSI/UL Std. XX."

For Canadian standards, the words "Certified to CAN/CSA Standard CXX No. XX." shall be used, or abbreviated, "Cert. to CAN/CSA Std. CXX No. XX."

Can be used together when both standards are used.

If all standards on the ATM have the same standard title, the shared title or its abbreviation may be used in place of the examples above. Example: "Medical Electrical Equipment" or "MEE"; "Information Technology Equipment" or "ITE"; "Audio/Video Information And Communication Technology Equipment" or "AV ICTE".

Note: A facsimile must be submitted to Intertek, Attn: Follow-up Services for approval prior to use.

The facsimile need not have a control number. A control number will be issued **after signed Certification Agreements** have been received by the Follow-up Services office, approval of the facsimile of your proposed Listing Mark, satisfactory completion of the Listing Report, and scheduling of a factory assessment in your facility.

MANUFACTURING AND PRODUCTION TESTS

Manufacturing and Production Tests shall be performed as required in this Report.

FOLLOW-UP SERVICE

Periodic unannounced audits of the manufacturing facility (and any locations authorized to apply the mark) shall be scheduled by Intertek. An audit report shall be issued after each visit. Special attention will be given to the following:

1. Conformance of the manufactured product to the descriptions in this Report.
2. Conformance of the use of the ETL mark with the requirements of this Report and the Certification Agreement.
3. Manufacturing changes.
4. Performance of specified Manufacturing and Production Tests.

In the event that the Intertek representative identifies non-conformance(s) to any provision of this Report, the Applicant shall take one or more of the following actions:

1. Correct the non-conformance.
2. Remove the ETL Mark from non-conforming product.
3. Contact the issuing product safety evaluation center for instructions.

10.1 Evaluation of Unlisted Components

Because Unlisted Components are uncontrolled, and they do not fall under a third party follow up program, Intertek may require these components to be tested and/or evaluated at least once annually, more often for certain components, as part of the independent certification process. The Unlisted Components in Section 5.0 require testing and/or evaluation as indicated.

The Applicant will be notified, in writing, via the applicable contact methods, as defined in Section 1.0, when these components must be selected and sent to Component Evaluation Center (CEC) for re-evaluation.

Due to particular testing requirements, some components may be requested to be shipped to specific labs. Thus, specific shipment destination(s) for each sample will be provided in the written notification.

Managing CEC Location:

Intertek Testing Services Shenzhen Limited Guangzhou Branch

ETL Component Evaluation Center

Room 02, &101/E201/E301/E401/E501/E601/E701/E801 of Room 01 1-8/F., No. 7-2,
Caipin Road, Science City

GETDD Guangzhou, Guangdong, China

Attn: Ms. Joey Kuang

Sample Disposition: Due to the destructive nature of the testing, all samples will be discarded at the conclusion of testing unless, the manufacturer specifically requests the return of the samples. The request for return must accompany the initial component shipment.

11.0 Manufacturing and Production Tests

The manufacturer agrees to conduct the following Manufacturing and Production Tests as specified:

Required Tests

- Dielectric Voltage Withstand Test
- Grounding Continuity Test

11.1 Dielectric Voltage Withstand Test

Method

Each unit shall withstand without breakdown, as a routine production-line test, the application of a potential:

- a) From input and output wiring, including connected components, to accessible dead metal parts that are able to become energized, and
- b) From input and output wiring to accessible low-voltage, limited-energy metal parts, including terminals.

The potential for the production-line test shall be in accordance with Condition A or Condition B of Table 67.1 at a frequency within the range of 40 – 70 Hertz.

A unit employing circuitry that is able to be damaged by an ac potential is able to be tested using a dc potential in accordance with Condition C or Condition D. Testing of a unit in a heated or unheated condition meets the intent of the requirement for manufacturing and production tests. The test is to be performed on a complete, fully assembled unit. It is not intended that the unit be unwired, modified, or disassembled for the test.

Table 67.1A
Production-line test conditions AC rated circuits

Circuit rating, Vac	Condition A		Condition B		Condition C		Condition D	
	Potential, volts ac	Time, seconds	Potential, volts ac	Time, seconds	Potential, volts dc	Time, seconds	Potential, volts dc	Time, seconds
250 or less	1000	60	1200	1	1400	60	1700	1
More than 250	1000+2 V ^a	60	1200+ 2.4 V ^a	1	1400+ 2.8 V ^a	60	1700+3.4 V ^a	1

^a Maximum marked voltage.

Note: The multipliers in the table are chosen with the following background:

2.4 – A 20% adder on the multiplier 2 to account for reduced test time.

2.8 – A $\sqrt{2}$, truncated after the first decimal (=1.4) multiplier on "2" from condition A to account for the peak value of an AC rms voltage to calculate the DC test potential of AC circuits.

3.4 – A combination of the two above: 2*1.2*1.4, rounded to the next decimal.

Table 67.1B
Production-line test conditions for DC rated circuits

Circuit rating, Vdc	Condition A		Condition B		Condition C		Condition D	
	Potential, volts ac	Time, seconds	Potential, volts ac	Time, seconds	Potential, volts dc	Time, seconds	Potential, volts dc	Time, seconds
250 or less	1000	60	1200	1	1400	60	1700	1
More than 250	1000+1.4 V ^a	60	1200+ 1.7 V ^a	1	1400+ 2 V ^a	60	1700+2.4 V ^a	1

^a Maximum marked voltage.

A unit employing a solid-state component that is not relied upon to reduce a risk of electric shock and that is susceptible to damage by the dielectric potential, is able to be tested before the component is electrically connected or after the component is electrically disconnected. The circuitry is able to be rearranged for the purpose of the test to minimize the potential of solid-state-component damage while retaining representative dielectric stress of the circuit.

During the test, the unit switches are to be in the on position, both sides of the input and output circuits of the unit are to be connected together and to one terminal of the test equipment, and the second test-equipment terminal is to be connected to the accessible dead metal.

11.1 Dielectric Voltage Withstand Test		
Products Requiring Dielectric Voltage Withstand Test:		
Product	Test Voltage	Test Time
1. From PV input to accessible low-voltage, limited-energy metal parts, including terminals.	1940Vdc	1s
2. From AC output to accessible low-voltage, limited-energy metal parts, including terminals	1500Vac or 2111Vdc	1s
All products covered by this Report.		
Product-One sample from each shipment of section 4.0 item 17:	Test Voltage	Test Time
Between prim.and sec.	1500Vac	60s
11.2 Grounding Continuity Test		
<u>Method</u>		
<p>Each product listed below shall be subjected to a test to determine that there is continuity between accessible dead-metal parts of the product and the grounding pin or blade of the attachment plug.</p> <p>If all accessible dead metal is connected, only a single test need be performed. A visual or audible device (ohmmeter, buzzer, etc.) may be used to indicate grounding continuity.</p>		
Products Requiring Grounding Continuity Test:		
All products covered by this Report.		

